



**Gas Hoses**  
**HG-2F-48K**

TAG:

SAFETY-LINK Gas Hose

**Architect/Engineering Specifications:**

48" coated gas appliance connector hose with 1 1/4" NPT male connections and installation kit. Certified to ANSI Z21.69 / CSA 6.16 and NSF 2.

Job Name \_\_\_\_\_  
 Model Specified \_\_\_\_\_ Quantity \_\_\_\_\_  
 Variations Specified \_\_\_\_\_  
 Date \_\_\_\_\_

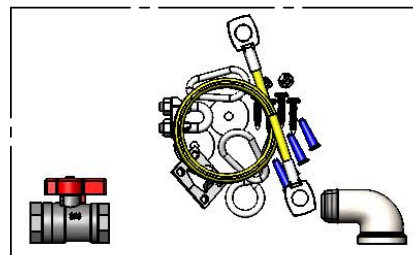
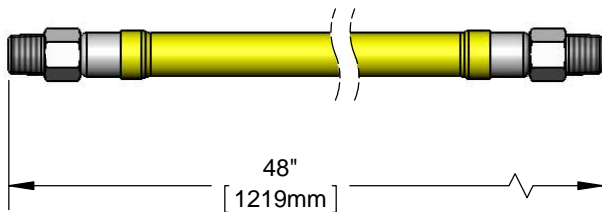
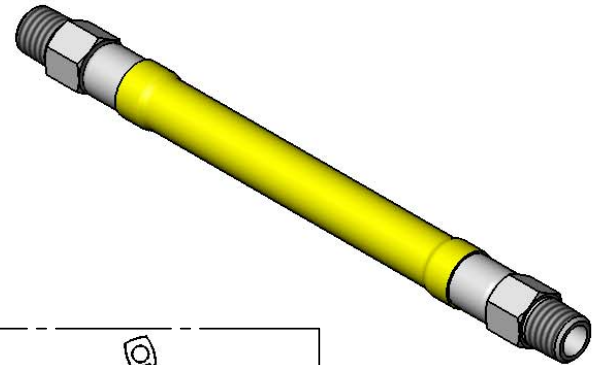

Installation Kit



90° Elbow

**Features & Benefits:**

- 48" coated gas appliance connector
- 1 1/4" NPT male freespin inlet
- 1 1/4" NPT male freespin outlet
- Installation kit
- 90° elbow included
- 360° rotatable hex nut rotates completely and freely
- Optimum torsional relief improves safety, increases connector life
- No lock-up during use with SwiveLink fitting
- Provides efficient, full gas flow
- Material: Extruded coated stainless steel braids

**Product Compliance:**

- ANSI Z21.69 / CSA 6.16
- NSF 2
- NFPA 54

**Warranty:** Five Year (Limited)

**Performance Data:**

- Gas Pressure: 1/2 psi max
- Temperature: 350° F max
- Capacity: 818,000 BTU / hr min



**T&S BRASS AND BRONZE WORKS, INC.**



• 2 Saddleback Cove • Travelers Rest, SC 29690  
 Ph 800-476-4103 • Fax 864-834-3518  
 • Simi Valley, CA • Ph 800-423-0150 • www.tsbrass.com

Date: 10/09/15