

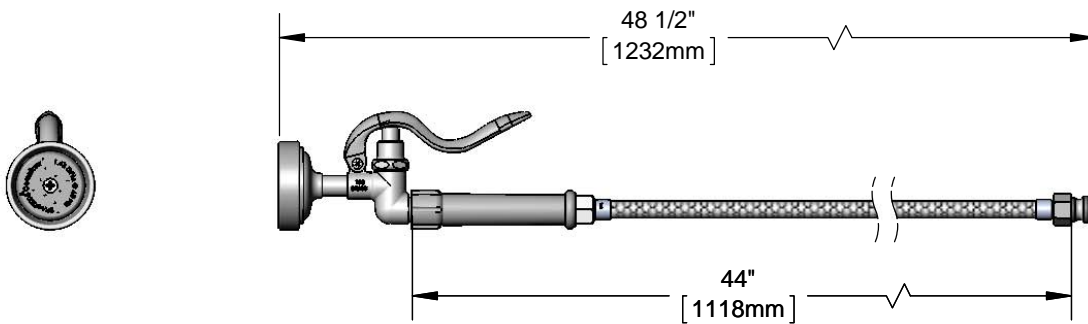

#### Architect/Engineering Specifications:

1.42 GPM spray valve with polished chrome plated brass body, 44" clear vinyl hose, heat resistant handle and 1/2" NPT male inlet. Certified to ASME A112.18.1/CSA B125.1, NSF 61-Section 9 and NSF 372. EPAAct 2005 compliant.

Job Name _____
Model Specified _____ Quantity _____
Variations Specified _____
Date _____

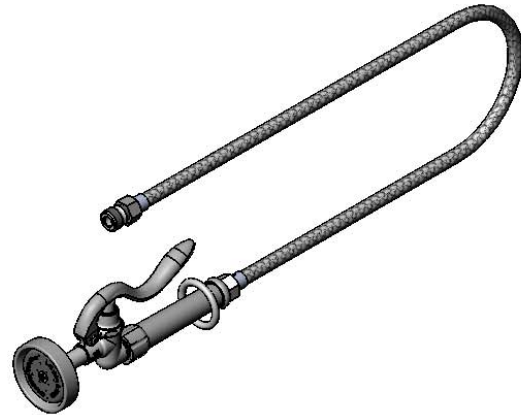

#### Features & Benefits:

- Designed for heavy-duty use in industrial kitchens
- 1.42 GPM spray valve
- 44" clear vinyl hose w/ heat resistant gray handle and hold down ring
- 1/2" NPT male inlet
- Material: Polished chrome plated brass body and clear vinyl hose

#### Product Compliance:

- ASME A112.18.1 / CSA B125.1
- NSF 61 - Section 9
- NSF 372 (Low Lead Content)
- EPAAct 2005 (PRSV)

#### Warranty: One Year (Limited)

#### Performance Data:

- Pressure: 20 - 125 psi
- Temperature: 40 °F - 140 °F
- Flow Rate: 1.42 GPM @ 60 psi

